

**APD-EPAP65S**



POWER  
YOUR  
FUTURE

**65 - 59 kW  
POWERED by PERKINS**

**DIESEL GENERATING SET 240/120V - 60 Hz - Single Phase**

MODEL		APD-EPAP65S	
Power Pf. 0.8	Standby	kVA	65
		kW	52
	Prime	kVA	59
		kW	47.2

Standby : Continuous running at variable load for duration of an emergency. No overload is permitted on these ratings. In accordance with ISO 3046 .  
 Prime : Continuous running at variable load for unlimited periods with 10% overload available for 1 hour in any 12 hour period. In accordance with ISO 8528,ISO 3046.

- High quality, reliable and complete power unit
- Compact design
- Easy start and maintenance possibility
- Every generating set is subject to a comprehensive test program which includes full load testing and checking and providing of all control and safety shut down functions testing
- Full engineered with a wide range of options and accessories: Canopy, sound proof canopy and on road trailer

**ENGINE**

- Heavy duty Perkins diesel engine
- Four stroke, water cooled, turbocharged
- Direct injection fuel system
- ECM governor system
- Replaceable fuel filter, oil filter and dry element air filter
- Cooling radiator and fan
- Starter battery (with lead acid) including Rack and Cables
- Flexible fuel connection hoses and manual oil sump drain valve
- Industrial capacity exhaust silencer and steel bellows
- Jacket water heater(at automatic models)
- Operation manuals and circuit diagram documents

**ALTERNATOR**

- Brushless, single bearing system, flexible disc, 4 poles
- Insulation class H
- Standard degree of protection IP21 (\*IP22/IP23 is avail.)
- Self-exciting and self-regulating
- Impregnation with tropicalised epoxy varnish
- Solid state Automatic Voltage Regulator
- Stator winding with 2/3 pitch for improved harmonics



Manufacturer reserves the right to make changes in model, technical specifications, color, equipment and accessories without prior notice.

## ENGINE



PERKINS		
Model	1104D-E44TG1	
EPA Certification	TIER 3	
Engine Power Output at rated rpm	BHP	96.2
	kWm	71.8
	HP	97.7
Aspiration and Cooling	Turbo charged	
Total Displacement	Cu.in.	268.5
	Litre	4.4
No. of Cylinders and Build	4-Inline	
Engine Speed	rpm	1800
Bore and Stroke	inches	4.13x5
	mmxmm	105x127
Compression Ratio	16.2:1	
Governor	ECM	
Starter Motor Voltage	12 V	
Fuel Consumption @ 100 % load	gal/hr	4.937
Fuel Consumption @ 75% load		4.356
Fuel Consumption @ 50% load		3.221
Fuel Consumption @ 25% load		1.716
Fuel Tank Capacity	gal. Litre	N/A
Oil Capacity	gal.	2.21
	Litre	8.4
Coolant Capacity	gal.	4.35
	Litre	16.5
Radiator Cooling Air	cfm m <sup>3</sup> /min	N/A
Air Intake – Engine	cfm	208.3
	m <sup>3</sup> /min	5.9
Exhaust Gas Flow	cfm	508.53
	m <sup>3</sup> /min	14.4
Standard operating temp degree of radiator	° C	40
Sound Level @1 meter / @ 7 meter	dB	TBD

## ALTERNATOR

Model	Marathon-GM-8.6-4
Size(mm)	365x292x375
Design	Brushless single bearing, revolving field
Stator	2/3 pitch
Rotor	Single bearing, flexible disc
Insulation System	Class H
Standard Temperature Rise	125 °C Prime / 150 °C Stand by
Exciter Type	Self Excited(PMG excitation is optional)
Phase Rotation	A (U), B (V), C (W)
Alternator Cooling	Direct drive centrifugal blower fan
AC Waveform Total Harmonic Distortion	No load < 1.5%. Non distorting balanced linear load < 5%
Telephone Influence Factor (TIF)	<50 per NEMA MG1-22.43
Telephone Harmonic Factor (THF)	<2%

## CONTROL SYSTEM

Control supervision and protection panel is mounted on the genset base frame. The control panel is equipped as follows:

### 1. Auto Mains Failure Control Panel

Panel equipments:

- ✓ Control with AMF module
- ✓ Static battery charger
- ✓ Emergency stop push button

### a) Generating set control module DSE 7320 features:

- ✓ The module is used to monitor a mains supply and starts and stops a standby generating set
- ✓ Micro-processor based design
- ✓ Automatic control of mains and generator contactors
- ✓ Monitors engine performance and AC power output
- ✓ LED alarm indication
- ✓ Front panel configuration of timers and alarm trip points
- ✓ Easy push button control  
STOP/RESET - MANUAL - TEST- AUTO - MUTE ALARM - START

### b) Metering via LED display:

- ✓ Generator Volts (L-L / L-N)
- ✓ Engine oil pressure (PSI-Bar)
- ✓ Generator Ampere (L1,L2,L3)
- ✓ Engine temperature (° C & ° F)
- ✓ Generator Frequency (Hz)
- ✓ Plant battery volts
- ✓ Engine hours run
- ✓ Mains Volts (Ph-Ph/Ph-N)
- ✓ Generator kVA, kWh
- ✓ Generator kW as % of rated kW setting
- ✓ Generator Cos (σ)

### 2. Power Outlet Terminal Board Mounted on the Gen-set Base frame



DSE 7320

### c) Alarms:

- ✓ Over and Under Speed
- ✓ Low and High Battery Volt.
- ✓ Start and Stop Failure
- ✓ Charge fail
- ✓ Over Current
- ✓ Under / Over Generator Voltage
- ✓ Low Oil Pressure
- ✓ Emergency stop
- ✓ High engine temperature
- ✓ kW overload
- ✓ Unbalanced load
- ✓ Independent earth fault trip

### d) LED Indications

Four configurable LED's like:

- ✓ Mains available
- ✓ Generator available
- ✓ Mains on load
- ✓ Generator on load

## OPTIONAL EQUIPMENTS

### Diesel Engine

- ✓ Oil heater

### Alternator

- ✓ 3/4 Pole Output Circuit Breaker
- ✓ Anti-condensation Heater

### Panel

- ✓ Charge ammeter
- ✓ Transfer Switch 3 Pole
- ✓ Transfer Switch 4 Pole
- ✓ Earth Fault ,single set

### Accessories

- ✓ Bulk fuel tank
- ✓ Automatic filling system
- ✓ Low fuel level alarm
- ✓ Residential silencer
- ✓ Enclosure or sound proof canopy
- ✓ Trailer
- ✓ Manual oil drain pump
- ✓ Tool kit for maintenance
- ✓ Fuel-water separator

## CHASSIS

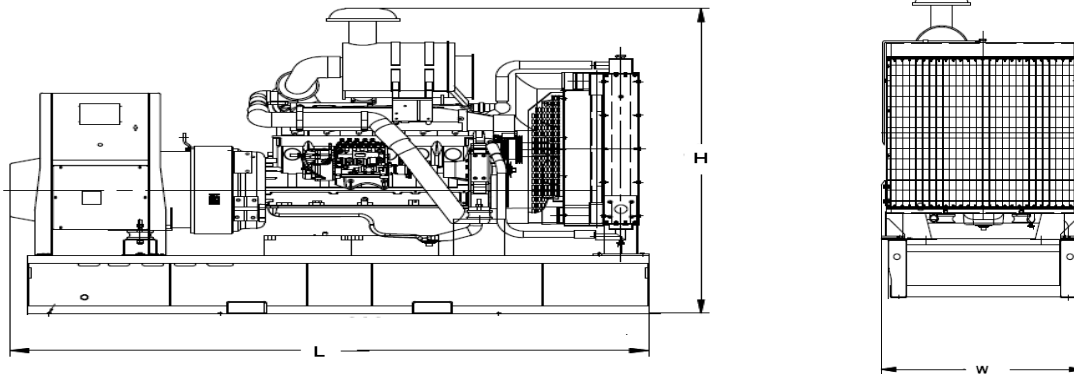

- ✓ The complete gen-set is mounted as whole on a heavy-duty fabricated, steel base frame
- ✓ Anti-vibration pads are fixed between the engine/ alternator feet and the base frame
- ✓ Base frame design incorporates an integral fuel tank (Up to 750 kVA) NON -UL
- ✓ The generating set can be lifted or carefully pushed/ pulled by the base frame
- ✓ Dial type fuel gauge and drain plug on the fuel tank
- ✓ Forklift pockets within base frame (up to 500kVA)

## DIMENSIONS

### OPEN TYPE

DIMENSIONS (LxWxH)	inches	<u>73.23x35.4x50.6</u>
	mm	1860x900x1295
DRY WEIGHT	Lb.	2376
	Kg	1078

### SOUND ATTENUATED TYPE

DIMENSIONS (LxWxH)	inches	<u>122.88x42.1x68</u>
	mm	3121x1068x1727
DRY WEIGHT	Lb.	3306
	Kg	1500

## CANOPY

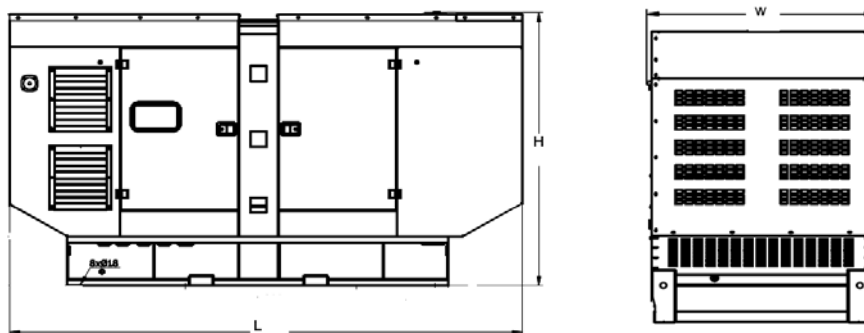

- ✓ All canopy parts are designed with modular principles
- ✓ Without welding assembly
- ✓ Doors on each side
- ✓ All metal canopy parts are painted by electrostatic polyester powder paint
- ✓ Exhaust silencer is protected against environment influences
- ✓ Thermally insulated engine exhaust system
- ✓ Emergency stop push button is installed outside of the canopy
- ✓ Easy lifting and moving
- ✓ Easy maintenance and operation

### AKSA USA

371 Exchange Street West Monroe, LA 71292

Tel:+1 318 855 8377 Fax:+1 318 855 8381

E-mail: sales@aksausa.com

[www.aksausa.com](http://www.aksausa.com)

Aksa Power Generation is a member of

