

**AVP415**



POWER  
YOUR  
FUTURE

**415kVA / 332kW  
POWERED by VOLVO**

**DIESEL GENERATING SET 400/230 V - 50 Hz - 3 Phase**

| MODEL            |         |     | AVP415 |
|------------------|---------|-----|--------|
| Power<br>Pf. 0.8 | Standby | kVA | 415    |
|                  |         | kW  | 332    |
|                  | Prime   | kVA | 380    |
|                  |         | kW  | 304    |

**Standby:** Continuous running at variable load for duration of an emergency. No overload is permitted on these ratings. In accordance with ISO 3046.  
**Prime:** Continuous running at variable load for unlimited periods with 10% overload available for 1 hour in any 12 hour period. In accordance with ISO 8528,ISO 3046.

- ✓ High quality, reliable and complete power unit
- ✓ Compact design
- ✓ Easy start and maintenance possibility
- ✓ Every generating set is subject to a comprehensive test program which includes full load testing, checking and provision of all control and safety shut down functions testing
- ✓ Fully engineered with a wide range of options and accessories: Canopy, sound proof canopy and off-road trailer



## ENGINE

### VOLVO PENTA

| Model                            |                     | TAD1343GE                            |
|----------------------------------|---------------------|--------------------------------------|
| Engine Power Output at rated rpm | kWm                 | 366                                  |
|                                  | HP                  | 498                                  |
| Aspiration and Cooling           |                     | Turbocharged-Change Air Cooled       |
| Total Displacement               | Litre               | 12.78                                |
| No. of Cylinders and Build       |                     | 6 Cylinder, In-Line                  |
| Engine Speed                     | rpm                 | 1500                                 |
| Bore and Stroke                  | mmxmm               | 131 x 158                            |
| Compression Ratio                |                     | 18.1:1                               |
| Governor                         |                     | Electronic control (Volvo / EMS 2.2) |
| Fuel Consumption at 100% load    | L/hr                | 75.7                                 |
| Fuel Consumption at 75% load     | L/hr                | 57                                   |
| Fuel Consumption at 50% load     | L/hr                | 39.4                                 |
| Fuel Tank Capacity               | Litre               | Open:700/Canopy:700                  |
| Oil Capacity                     | Litre               | 36                                   |
| Coolant Capacity                 | Litre               | 44                                   |
| Radiator Cooling Air             | m <sup>3</sup> /min | 337.6                                |
| Air Intake – Engine              | m <sup>3</sup> /min | 27                                   |
| Exhaust Gas Flow                 | m <sup>3</sup> /min | 60                                   |

- ✓ Heavy duty Volvo Penta diesel engine
- ✓ Four stroke, water cooled, turbocharged
- ✓ Direct injection fuel system
- ✓ Electronic Governor system
- ✓ 24 V D.C. starter and charge alternator
- ✓ Replaceable fuel filter, oil filter and dry element air filter

- ✓ Cooling radiator and fan
- ✓ Starter battery (with lead acid) including Rack and Cables
- ✓ Flexible fuel connection hoses and manual oil sump drain valve
- ✓ Industrial capacity exhaust silencer and steel bellows
- ✓ Operation manuals and circuit diagram documents

## ALTERNATOR

|                                       |  |
|---------------------------------------|--|
| Design                                | Brushless single bearing, revolving field                |
| Stator                                | 2/3 pitch  |
| Rotor                                 | Single bearing, flexible disc                            |
| Insulation System                     | Class H  |
| Standard Temperature Rise             | 125 - 163°C Continuous                                   |
| Exciter Type                          | Self Excited   |
| Phase Rotation                        | A (U), B (V), C (W)                                      |
| Alternator Cooling                    | Direct drive centrifugal blower fan                      |
| AC Waveform Total Harmonic Distortion | No load < 1.5%. Non distorting balanced linear load < 5% |
| Telephone Influence Factor (TIF)      | <50 per NEMA MG1-22.43                                   |
| Telephone Harmonic Factor (THF)       | <2%  |

- ✓ Brushless, single bearing system, flexible disc, 4 poles
- ✓ Insulation class H
- ✓ Standard degree of protection IP23
- ✓ Self-exciting and self-regulating

- ✓ All wound components are impregnated with materials and processes designed specifically
- ✓ Solid state Automatic Voltage Regulator
- ✓ Stator winding with 2/3 pitch for improved harmonics

## CONTROL SYSTEM

Control supervision and protection panel is mounted on the genset base frame. The control panel is equipped as follows:

### 1. Auto Mains Failure Control Panel

Panel equipments:

- ✓ Control with AMF module
- ✓ Static battery charger
- ✓ Emergency stop push button

### a) Generating set control module DSE 7320 features:

- ✓ The module is used to monitor a mains supply and starts and stops a standby generating set
- ✓ Micro-processor based design
- ✓ Automatic control of mains and generator contactors
- ✓ Monitors engine performance and AC power output
- ✓ LED alarm indication
- ✓ Front panel configuration of timers and alarm trip points
- ✓ Easy push button control  
STOP/RESET - MANUAL - TEST- AUTO - MUTE ALARM - START

### b) Metering via LED display:

- ✓ Generator Volts (L-L / L-N)
- ✓ Engine oil pressure (PSI-Bar)
- ✓ Generator Ampere (L1,L2,L3)
- ✓ Engine temperature (° C & ° F)
- ✓ Generator Frequency (Hz)
- ✓ Plant battery volts
- ✓ Engine hours run
- ✓ Mains Volts (Ph-Ph/Ph-N)
- ✓ Generator kVA, kWh
- ✓ Generator kW as % of rated kW setting
- ✓ Generator Cos ( $\sigma$ )

### 2. Power Outlet Terminal Board Mounted on the Genset Base Frame



DSE 7320

### c) Alarms:

- ✓ Over and Under Speed
- ✓ Low and High Battery Volt.
- ✓ Start and Stop Failure
- ✓ Charge fail
- ✓ Over Current
- ✓ Under / Over Generator Voltage
- ✓ Low Oil Pressure
- ✓ Emergency stop
- ✓ High engine temperature
- ✓ kW overload
- ✓ Unbalanced load
- ✓ Independent earth fault trip

### d) LED indications

Four configurable LED's like:

- ✓ Mains available
- ✓ Generator available
- ✓ Mains on load
- ✓ Generator on load

## OPTIONAL EQUIPMENTS

### Diesel Engine

- ✓ Oil heater

### Alternator

- ✓ 3/4 Pole Output Circuit Breaker
- ✓ Anti-condensation Heater

### Panel

- ✓ Charge ammeter
- ✓ Transfer Switch 3 Pole
- ✓ Transfer Switch 4 Pole
- ✓ Earth Fault ,single set

### Accessories

- ✓ Bulk fuel tank
- ✓ Automatic filling system
- ✓ Fuel-water separator filter
- ✓ Low fuel level alarm
- ✓ Residential silencer
- ✓ Enclosure or sound proof canopy
- ✓ Trailer
- ✓ Manual oil drain pump
- ✓ Tool kit for maintenance

## CHASSIS

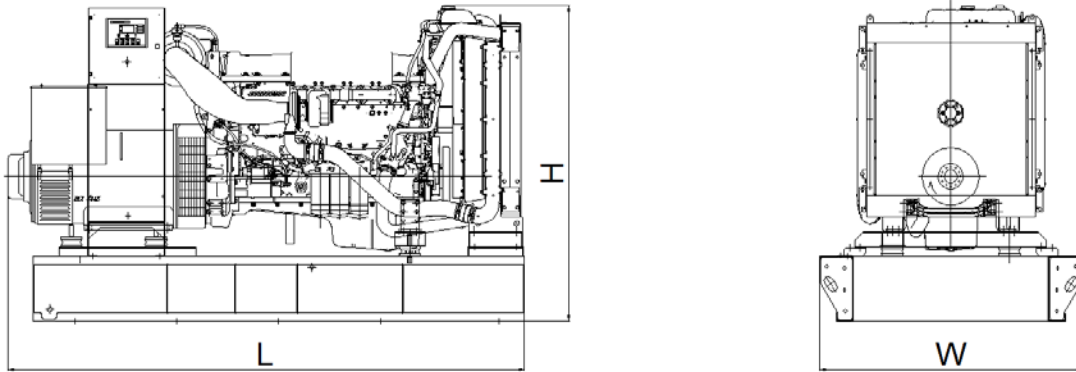

- ✓ The complete gen-set is mounted as whole on a heavy-duty fabricated, steel base frame
- ✓ Anti-vibration pads are fixed between the engine/ alternator feet and the base frame
- ✓ Base frame design incorporates an integral fuel tank (Up to 750 kVA)
- ✓ The generating set can be lifted or carefully pushed / pulled by the base frame
- ✓ Dial type fuel gauge and drain plug on the fuel tank

## DIMENSIONS

| OPEN TYPE          |    |                |
|--------------------|----|----------------|
| DIMENSIONS (LxWxH) | mm | 3138x1550x1855 |
| DRY WEIGHT         | kg | 3470           |
| CANOPY TYPE        |    |                |
| DIMENSIONS (LxWxH) | mm | 4463x1606x2488 |
| DRY WEIGHT         | kg | 4340           |

## CANOPY

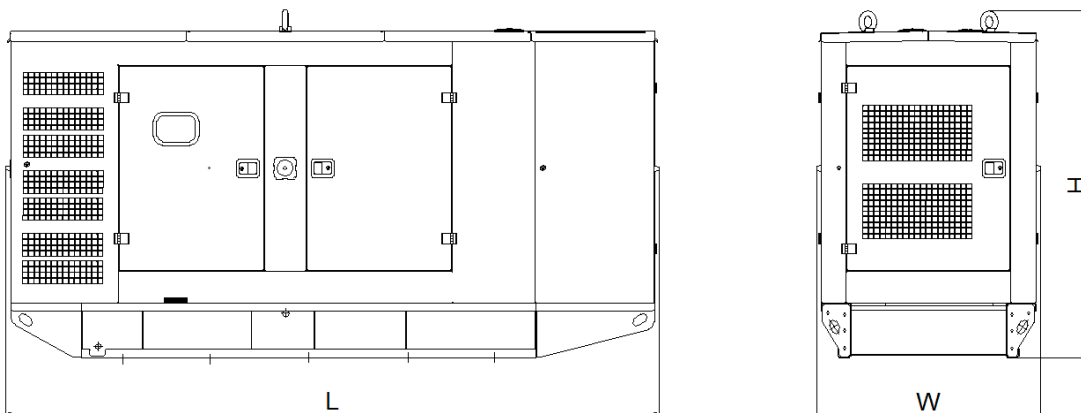

- ✓ All canopy parts are designed with modular principles
- ✓ Without welding assembly
- ✓ Doors on each side
- ✓ All metal canopy parts are painted by electrostatic polyester powder paint
- ✓ Exhaust silencer is protected against environment influences
- ✓ Thermally insulated engine exhaust system
- ✓ Emergency stop push button is installed outside of the canopy
- ✓ Easy lifting and moving
- ✓ Easy maintenance and operation

### Aksa Power Generation

Evren Mah.Gulbahar Caddesi 1.Sokak Gunesli-Istanbul-TURKEY

Tel:+90 212 478 66 66

Fax:+90 212 657 55 16

E-mail: aksa@aksapowergen.com

[www.aksapowergen.com](http://www.aksapowergen.com)

Aksa Power Generation is a member of  KAZANCI HOLDING [www.aksa.com.tr](http://www.aksa.com.tr)