

APD-EPAM2000



POWER
YOUR
FUTURE

**2500 kVA/ 2000 kW
POWERED by MITSUBISHI**

DIESEL GENERATING SET 480/277 V, 208/120V - 60 Hz

MODEL		APD-EPAM2000	
Power Pf. 0.8	Standby	kVA	2500
		kW	2000
	Prime	kVA	2250
		kW	1800

Standby : Continuous running at variable load for duration of an emergency. No overload is permitted on these ratings. In accordance with ISO 3046 .

Prime : Continuous running at variable load for unlimited periods with 10% overload available for 1 hour in any 12 hour period. In accordance with ISO 8528,ISO 3046.

- High quality, reliable and complete power unit
- Compact design
- Easy start and maintenance possibility
- Every generating set is subject to a comprehensive test program which includes full load testing and checking and providing of all control and safety shut down functions testing
- Full engineered with a wide range of options and accessories: Canopy, sound proof canopy and on road trailer

ENGINE

- Heavy duty Mitsubishi diesel engine
- Four stroke, water cooled, turbocharged
- Direct injection fuel system
- Electric governor system
- Replaceable fuel filter, oil filter and dry element air filter
- Cooling radiator and fan
- Starter battery (with lead acid) including Rack and Cables
- Flexible fuel connection hoses and manual oil sump drain valve
- Industrial capacity exhaust silencer and steel bellows
- Jacket water heater(at automatic models)
- Operation manuals and circuit diagram documents

ALTERNATOR

- Brushless, single bearing system, flexible disc, 4 poles
- Insulation class H
- Standard degree of protection IP21 (*IP22/IP23 is avail.)
- Self-exciting and self-regulating
- Impregnation with tropicalised epoxy varnish
- Solid state Automatic Voltage Regulator
- Stator winding with 2/3 pitch for improved harmonics



Manufacturer reserves the right to make changes in model, technical specifications, color, equipment and accessories without prior notice.

ENGINE

MITSUBISHI		
Model	S16R-Y2PTAW2	
EPA Certification	TIER 2	
Engine Power Output at rated rpm	BHP	2923
	kWm	2180
	HP	2923
Aspiration and Cooling	Turbocharged	
Total Displacement	Cu.in.	3989
	Litre	65.37
No. of Cylinders and Build	16V	
Engine Speed	rpm	1800
Bore and Stroke	inches	6.69x7.09
	mmxmm	170x180
Compression Ratio	14.0:1	
Governor	Electric	
Starter Motor Voltage	24 V x 2 pieces	
Fuel Consumption @ 100 % load	gal/hr	141.97
Fuel Consumption @ 75% load		106.22
Fuel Consumption @ 50% load		71.38
Fuel Consumption @ 25% load		40.47
Fuel Tank Capacity	gal. Litre	N/A
Oil Capacity	gal.	52.8
	Litre	200
Coolant Capacity	gal.	44.9
	Litre	170
Radiator Cooling Air	cfm	74600
	m ³ /min	2112
Air Intake – Engine	cfm	7274
	m ³ /min	206
Exhaust Gas Flow	cfm	17302
	m ³ /min	490
Standard operating temp degree of radiator	° C	40
Sound Level @1 meter / @ 7 meter	dB	N/A

ALTERNATOR

Model	Marathon-MX-1540-4
Size(mm)	1998x960x1300
Design	Brushless single bearing, revolving field
Stator	2/3 pitch
Rotor	Single bearing, flexible disc
Insulation System	Class H
Standard Temperature Rise	125 °C Prime / 150 °C Stand by
Exciter Type	Self Excited(PMG excitation is optional)
Phase Rotation	A (U), B (V), C (W)
Alternator Cooling	Direct drive centrifugal blower fan
AC Waveform Total Harmonic Distortion	No load < 1.5%. Non distorting balanced linear load < 5%
Telephone Influence Factor (TIF)	<50 per NEMA MG1-22.43
Telephone Harmonic Factor (THF)	<2%

CONTROL SYSTEM

Control supervision and protection panel is mounted on the genset base frame. The control panel is equipped as follows:

1. Auto Mains Failure Control Panel

Panel equipments:

- ✓ Control with AMF module
- ✓ Static battery charger
- ✓ Emergency stop push button



DSE 7320

a) Generating set control module DSE 7320 features:

- ✓ The module is used to monitor a mains supply and starts and stops a standby generating set
- ✓ Micro-processor based design
- ✓ Automatic control of mains and generator contactors
- ✓ Monitors engine performance and AC power output
- ✓ LED alarm indication
- ✓ Front panel configuration of timers and alarm trip points
- ✓ Easy push button control
STOP/RESET - MANUAL - TEST- AUTO - MUTE ALARM - START

b) Metering via LED display:

- ✓ Generator Volts (L-L / L-N)
- ✓ Engine oil pressure (PSI-Bar)
- ✓ Generator Ampere (L1,L2,L3)
- ✓ Engine temperature (° C & ° F)
- ✓ Generator Frequency (Hz)
- ✓ Plant battery volts
- ✓ Engine hours run
- ✓ Mains Volts (Ph-Ph/Ph-N)
- ✓ Generator kVA, kWh
- ✓ Generator kW as % of rated kW setting
- ✓ Generator Cos (σ)

c) Alarms:

- ✓ Over and Under Speed
- ✓ Low and High Battery Volt.
- ✓ Start and Stop Failure
- ✓ Charge fail
- ✓ Over Current
- ✓ Under / Over Generator Voltage
- ✓ Low Oil Pressure
- ✓ Emergency stop
- ✓ High engine temperature
- ✓ kW overload
- ✓ Unbalanced load
- ✓ Independent earth fault trip

d) LED Indications

Four configurable LED's like:

- ✓ Mains available
- ✓ Generator available
- ✓ Mains on load
- ✓ Generator on load

2. Power Outlet Terminal Board Mounted on the Gen-set Base frame

OPTIONAL EQUIPMENTS

Diesel Engine

- ✓ Oil heater

Alternator

- ✓ 3/4 Pole Output Circuit Breaker
- ✓ Anti-condensation Heater

Panel

- ✓ Charge ammeter
- ✓ Transfer Switch 3 Pole
- ✓ Transfer Switch 4 Pole
- ✓ Earth Fault ,single set

Accessories

- ✓ Bulk fuel tank
- ✓ Automatic filling system
- ✓ Low fuel level alarm
- ✓ Residential silencer
- ✓ Enclosure or sound proof canopy
- ✓ Trailer
- ✓ Manual oil drain pump
- ✓ Tool kit for maintenance
- ✓ Fuel-water separator

CHASSIS

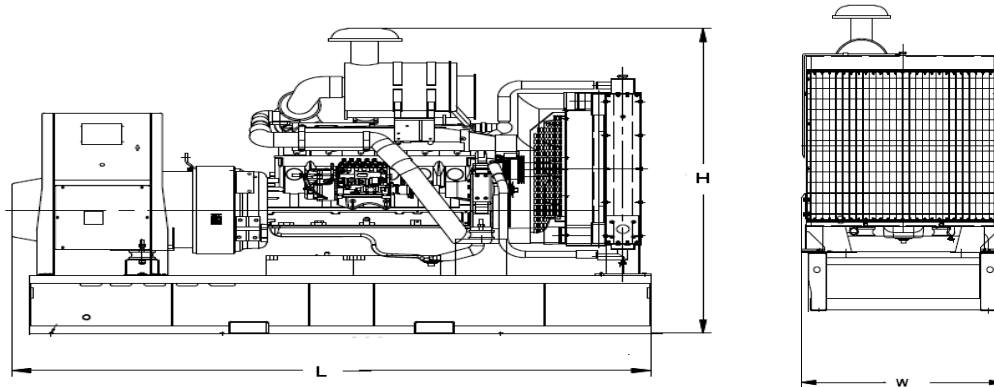

- ✓ The complete gen-set is mounted as whole on a heavy-duty fabricated, steel base frame
- ✓ Anti-vibration pads are fixed between the engine/ alternator feet and the base frame
- ✓ Base frame design incorporates an integral fuel tank (Up to 750 kVA) NON -UL
- ✓ The generating set can be lifted or carefully pushed/ pulled by the base frame
- ✓ Dial type fuel gauge and drain plug on the fuel tank
- ✓ Forklift pockets within base frame (up to 500kVA)

DIMENSIONS

OPEN TYPE		
DIMENSIONS (LxWxH)	inches	222.3x93.6x132.2
	mm	5646x2380x3358
DRY WEIGHT	Lb.	34100
	Kg	15467
SOUND ATTENUATED TYPE		
DIMENSIONS (LxWxH)	inches	ISO40FT
	mm	
DRY WEIGHT	Lb.	N/A
	Kg	

CANOPY

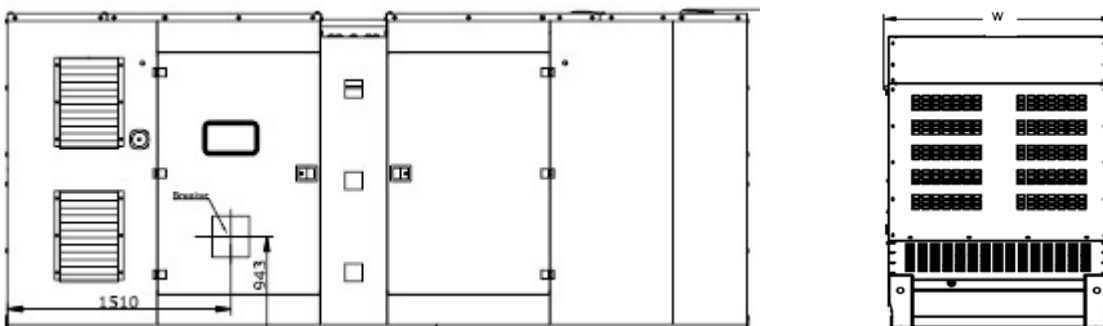

- ✓ All canopy parts are designed with modular principles
- ✓ Without welding assembly
- ✓ Doors on each side
- ✓ All metal canopy parts are painted by electrostatic polyester powder paint
- ✓ Exhaust silencer is protected against environment influences
- ✓ Thermally insulated engine exhaust system
- ✓ Emergency stop push button is installed outside of the canopy
- ✓ Easy lifting and moving
- ✓ Easy maintenance and operation

AKSA USA

371 Exchange Street West Monroe, LA 71292

Tel:+1 318 855 8377 Fax:+1 318 855 8381

E-mail: sales@aksausa.com

www.aksausa.com